



PSBSH 1012B

v.1.0

PSBSH 13,8V/1A/7Ah/HERMETIC

Buffer switch mode power supply unit

EN*

Edition: 1'st from 16 th of November 2011

Supercedes the ----- edition.

Features:

- DC 13,8V/1A uninterruptible power supply
- fitting battery: 7Ah/12V
- high efficiency 70%
- battery charging and maintenance control
- excessive discharging (UVP) protection
- battery output full protection against short-circuit and reverse polarity connection
- jumper selectable battery charge current 0,2A/0,5A
- START facility for manual battery connection
- LED indication
- FAC indication of the 230V power collapse
- adjustable times indicating 230V power failure
- protections:
 - SCP short-circuit protection
 - OLP overload protection
 - OHP overheat protection
 - overvoltage protection
 - against sabotage
 - IP65 ABS, hermetic enclosure

CONTENTS:

1. Technical description.
 - 1.1 General description
 - 1.2 Block diagram
 - 1.3 Description of PSU components and connectors.
 - 1.4 Specifications
2. Installation.
 - 2.1 Requirements
 - 2.2 Installation procedure
3. Operating status indication.
 - 3.1 LED indication of operating status
 - 3.2 Technical output
4. Operation and use.
 - 4.1 Overload or short circuit of the PSU output
 - 4.2 Battery-assisted operation
 - 4.3 Maintenance

1. Technical description

1.1 General description

A buffer PSU is intended for an uninterrupted supply to alarm systems devices requiring stabilized voltage of **12V/DC (+/-15%)**. The PSU provides voltage of **13,8 V DC**. Current efficiency:



1. Output current **1,0A (without battery)**
2. Output current **0,8A + 0,2A battery charge**
3. Output current **0,5A + 0,5A battery charge**

Total device current + battery: 1A max.

In case of power decay, a battery back-up is activated immediately. Battery charge current is preset to 0,5A. The PSU is located in an ABS enclosure which can accommodate a 7Ah/12V battery and features a microswitch indicating door opening (front cover).

OPTIONAL POWER SUPPLY CONFIGURATIONS: (visualisation available at: www.pulsar.pl)

1. Buffer power supply **PSBSH 13,8V/2x0,5A/7Ah**
- PSBSH 1012B + LB2 2x0,5A (AWZ586) + 7Ah
2. Buffer power supply **PSBSH 13,8V/4x0,3A/7Ah**
- PSBSH 1012B + LB4 4x0,3A (AWZ574, AWZ576) + 7Ah
3. Buffer power supply **PSBSH 13,8V/12V/2A/7Ah**
- PSBSH 1012B + RN250 (13,8V/12V) + 7Ah
4. Buffer power supply **PSBSH 13,8V/5V÷7,4V/2A/7Ah**
- PSBSH 1012B + DCDC20 (5V÷7,4V/2A) + 7Ah

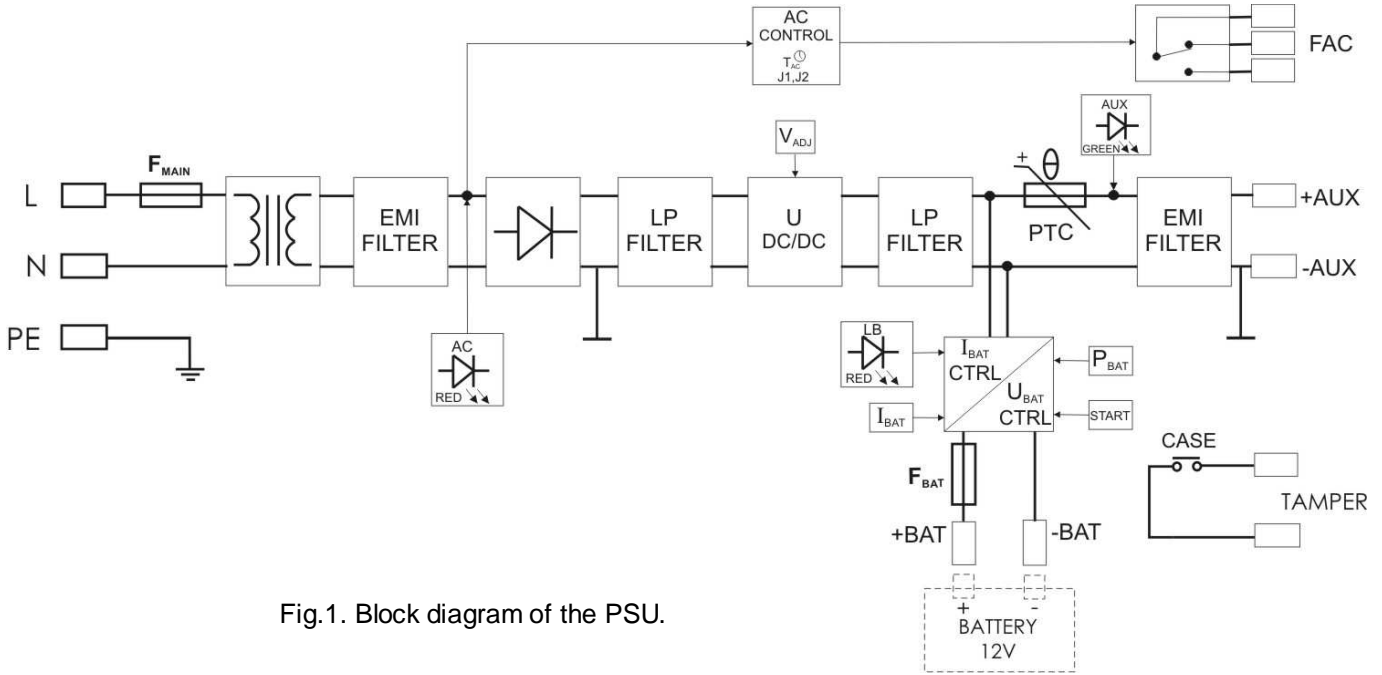

Fig.1. Block diagram of the PSU.

1.3 Description of PSU components and connectors.

Table 1. Elements of the PSU pcb (refer to chart 2).

Element no.	Description
[1]	<p>P_{BAT}; pins - configuration of UVP battery protection function</p> <ul style="list-style-type: none"> • P_{BAT} = <input checked="" type="checkbox"/> protection (disconnection) of the battery off • P_{BAT} = <input type="checkbox"/> protection (disconnection) of the battery on <p>T_{AC}; pins J1, J2 - configuration of time lag of AC failure indication</p> <ul style="list-style-type: none"> • J1= <input type="checkbox"/>, J2= <input type="checkbox"/> time lag T= 5s • J1= <input type="checkbox"/>, J2= <input checked="" type="checkbox"/> time lag T= 140s • J1= <input checked="" type="checkbox"/>, J2= <input type="checkbox"/> time lag T= 1040s (17m 20s) • J1= <input checked="" type="checkbox"/>, J2= <input checked="" type="checkbox"/> time lag T= 2h 20m 30s <p>Legend: <input checked="" type="checkbox"/> jumper installed <input type="checkbox"/> jumper removed</p>
[2]	START button (launching from battery)
[3]	V _{ADJ} potentiometer, voltage adjustment DC
[4]	F _{BAT} fuse in the battery circuit
[5]	<p>Connectors:</p> <p>+BAT- DC supply output of the battery (+BAT= red, -BAT=black)</p> <p>+AUX- DC supply output (+AUX= +U, -AUX=GND)</p> <p>FAC - AC absence technical output – relay assisted</p> <p>Caution! In Fig.2. the set of contacts indicates potential-free status which corresponds to AC power failure.</p>
[6]	<p>LED indication:</p> <p>AC - LED for AC voltage</p> <p>LB - LED for battery charge</p> <p>AUX - LED for DC voltage</p>
[7]	Connector to the external LED indicators: AC and AUX.
[8]	<p>I_{BAT}; pins – battery charge current selection</p> <ul style="list-style-type: none"> • J1= <input checked="" type="checkbox"/> J2= <input checked="" type="checkbox"/> I_{bat} =0,2 A • J1= <input type="checkbox"/> J2= <input checked="" type="checkbox"/> I_{bat} =0,5 A <p>Legend: <input checked="" type="checkbox"/> jumper installed <input type="checkbox"/> jumper removed</p>

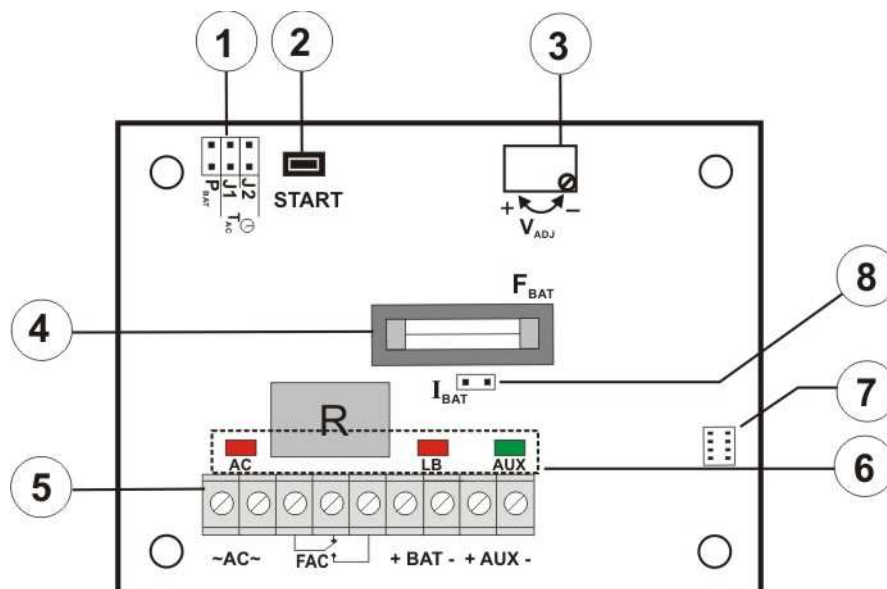

Fig.2. View of the pcb.

Table 2. Elements of the PSU (refer to chart 3).

Element no.	Description
[1]	Isolation transformer
[2]	Power supply unit board (tab. 1, fig. 2)
[3]	TAMPER ; microswitches (contacts) for sabotage protection (NC)
[4]	F_{MAIN} fuse in the power supply circuit (230V/AC)
[5]	L-N connector 230V/AC, PE protection connector
[6]	Battery connectors +BAT = red, - BAT = black

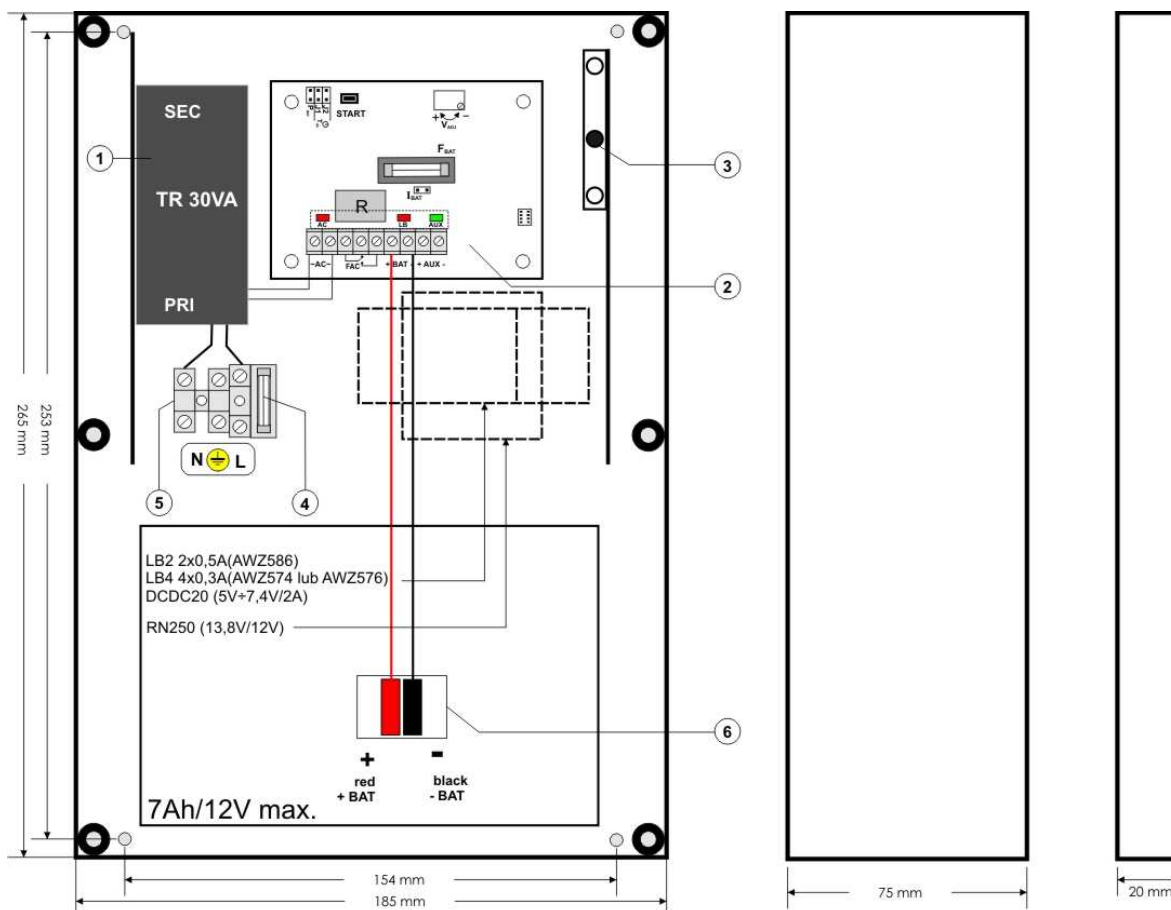

Fig.3. The view of the PSU.

1.4 Specifications:

- electrical parameters (tab.3)
- mechanical parameters (tab.4)
- operation safety (tab.5)
- operating parameters (tab.6)

Electrical parameters (tab. 3)

Mains supply	230V/AC (-15%/+10%)
Current up to	0,14 A
Power frequency	50Hz
Supply power	17 W
Efficiency	70%
Output voltage	11,0 V ÷ 13,8 V DC – buffer operation 10,0 V ÷ 13,8 V DC – battery-assisted operation
Output current	1,0A (without battery) 0,8A + 0,2A battery charge 0,5A + 0,5A battery charge
Output voltage setting, escalation and keeping time	10ms / 34ms / 12ms
Voltage adjustment range	12,0 V ÷ 14,5 V
Ripple	30 mV p-p max.
Current consumption by PSU systems	13 mA – battery assisted operation
Battery charge current	0,2A / 0,5A - I _{BAT} jumper selectable
Short-circuit protection SCP	200% ÷ 250% of supply power current limitation and/or fuse damage in the battery circuit (fuse-element replacement required)
Overload protection OLP	110% ÷ 150% (@25°C) of power supply - limitation with the PTC automatic fuse, manual restart (the fault requires the disconnection of the DC output circuit)
Battery circuit SCP and reverse polarity protections	2A - current limitation, F _{BAT} fuse (in case of a failure, fuse-element replacement required)
Excessive discharge protection UVP	U<10,0 V (± 5%) – disconnection of (- BAT) battery, configuration by the P _{BAT} jumper
Technical outputs: - FAC; indicates AC power failure - TAMPER indicates enclosure opening	- R-relay type, 1A@ 30Vdc/50Vac max. time lag about 5s/140s/1040s/2h20m30s (+/-5%) - microswitch, NC contacts (enclosure closed), 0,5A@50V DC (max.)
F _{BAT} fuse F _{MAIN} fuse	F2A / 250V T315mA / 250V

Mechanical parameters (tab. 4).

Enclosure dimensions	185 x 265 x 95 (WxHxD) [mm] (+/- 2)
Fixation	154 x 253 x Φ 6 x4 (WxH)
Fitting battery	7Ah/12V (SLA) max.
Net/gross weight	2,0/2,2 kg
Enclosure colour	ABS, IP65, light grey
Closing	Cheese head screw (at the front), lock assembly possible
Connectors	Power-supply: Φ0,63÷2,50 (AWG 22-10) Outputs: Φ0,41÷1,63 (AWG 26-14), Battery output BAT: 6,3F-2,5, 30cm, TAMPER output: wires, 30cm
Notes	The enclosure has a removable mounting board with the PSU systems.

Operation safety (tab.5).

Protection class PN-EN 60950-1:2007	I (first)
Degree of Protection PN-EN 60529: 2002 (U)	IP65 glands installation required: P9 (Φ 4-8mm) x2 P13,5 (Φ 6-12mm) x1
Electrical strength of insulation: - between input and output circuits of the PSU (I/P-O/P)	3000 V/AC min.

- between input circuit and PE protection circuit (I/P-FG) - between output circuit and PE protection circuit (O/P-FG)	1500 V/AC min. 500 V/AC min.
Insulation resistance: - between input circuit and output or protection circuit	100 MΩ, 500V/DC

Operating parameters (tab.6).

Operating temperature	-10°C...+40°C
Storage temperature	-20°C...+60°C
Relative humidity	20%...90%, without condensation
Vibrations during operation	unacceptable
Impulse waves during operation	unacceptable
Direct insulation	unacceptable
Vibrations and impulse waves during transport	According to PN-83/T-42106

2. Installation

2.1 Requirements

The buffer PSU shall be mounted by a qualified installer with appropriate permissions and qualifications for 230V/AC installations and low-voltage installations (required and necessary for a given country). The device shall be mounted in confined spaces, according to the environment class II, with normal air humidity (RH=90% max. without condensation) and the temperature from -10°C to +40°C. The PSU shall operate in a vertical or horizontal position.



1. Output current 1,0A (without battery)
2. Output current 0,8A + 0,2A battery charge
3. Output current 0,5A + 0,5A battery charge

Total device current + battery: 1A max.

As the PSU is designed for a continuous operation and is not equipped with a power-switch, therefore an appropriate overload protection shall be guaranteed in the power supply circuit. Moreover, the user shall be informed about the method of unplugging (usually through assigning an appropriate fuse in the fuse-box). The electrical system shall follow valid standards and regulations.

2.2 Installation procedure

1. Before installation, cut off the voltage in the 230V power-supply circuit.

2. Mount the glands (in a set, P9:Φ 4-8mm x2; P13,5: Φ 6-12mm x1) in the enclosure, considering the diameter of power supply and receivers wires. Mind the location of the battery and additional equipment.
3. Mount the PSU in a selected location and connect the wires. (with the gland)
4. Connect the power cables (~230Vac) to L-N clips of the PSU. Connect the ground wire to the clip marked by the earth symbol PE (PSU module connector). Use a three-core cable (with a yellow and green PE protection wire) to make the connection. Lead the cables to the appropriate clips through the insulating bushing of the connection board.



The shock protection circuit shall be performed with a particular care, i.e. the yellow and green wire coat of the power cable shall stick to one side of the terminal - marked with

⚡ symbol on the PSU enclosure. Operation of the PSU without the properly made and fully operational shock protection circuit is UNACCEPTABLE! It can cause a device failure or an electric shock.

5. Connect the receivers' wires to the +AUX, -AUX terminals of the terminal box on the PSU pcb.
6. If necessary, connect the device conductors to the technical outputs:
 - FAC; AC status indication (alarm panel, controller, indicator, LED, etc.) Use the T_{AC} (J1,J2) jumper to determine the indication time lag.
 - TAMPER; the indicator preventing the PSU from unwanted opening
7. Allowing of the battery parameters, determine the maximum charging current using the I_{BAT} pins.
8. Using the P_{BAT} pins, determine whether the function of disconnecting the discharged battery U<10V (+/-5%) is to be on or off. **The battery protection is on if the P_{BAT} jumper is removed.**
9. Activate the ~230V/AC supply (the AC red diode and AUX diode should be permanently illuminated)
10. Check the output voltage (the PSU voltage without load should amount to 13,6 V÷ 13,9 V, during battery charging 11 V÷ 13,8 V). If the value of the voltage requires adjustment, it should be set by the V_{ADJ} potentiometer, monitoring the voltage at the AUX output of the PSU.

11. Connect the battery in accordance with the signs: +BAT red to 'plus', -BAT black to 'minus', (the LB diode light should fade throughout the time of charging).
12. Once the tests and control operation have been completed, close the PSU.

3. Operating status indication.

3.1 LED indication of operating status

The PSU is equipped with three diodes: AC, LB, AUX. They are placed on the pcb of the PSU and indicate its operation status.

- **AC - red diode:** under normal status (AC supply) the diode is permanently illuminated. The absence of AC supply is indicated by the AC diode going off.
- **LB - red diode:** indicates the battery charging process; the intensity of illumination is dependent on the charging current.
- **AUX - green diode:** indicates the DC supply status in the output of the PSU. Under normal status, the diode is permanently illuminated. In case of short-circuit or overload, the diode goes off.

3.2 Technical outputs:

The PSU is equipped with indication outputs.

- **FAC - absence of AC supply output:** - relay output indicates the absence of AC supply. In case of power loss, the PSU will switch the relay contacts after a time period set by the T_{AC} jumpers (J1, J2).



Caution! In Fig.2. the contact set in the potential-free status corresponds to a state with no AC power (AC power failure).

- **TAMPER - output indicates opening the power-supply unit:** output as volt-free (potential-free) contacts which indicate power-supply unit door status, unit closed: NC, unit opened: NO

4. Operation and use.

4.1 Overload or short circuit of the PSU output

The AUX output of the PSU is equipped with the PTC polymer fuse protection. If the load of the PSU exceeds I_{max} (load 110% ÷ 150% @25°C of the PSU power), the output voltage is automatically cut off and indicated by the green diode going off. Cut off the output load for approximately 1 minute to restore the output power.

In case of the short-circuit to the AUX, BAT output, (load 200% ÷ 250% of the PSU power) or incorrect connection of the battery, the fuse F_{BAT} in the battery circuit becomes permanently damaged and the restoration of the voltage at the BAT output requires the replacement of the fuse.

4.2 Battery-assisted operation

Immediate battery reverting in case of main power outage.

In order to run the PSU from the battery only, connect the BAT connectors in accordance with the signs: + BAT red to 'plus' and, - BAT black to 'minus' then press the START button on the main board and hold it for 5 seconds.



The PSU contains a discharged battery disconnection system (UPV), configured through the P_{BAT} pins. The battery protection is on after removing the P_{BAT} jumper.

4.3 Maintenance

Any and all maintenance operations may be performed following the disconnection of the PSU from the power supply network. The PSU does not require performing any specific maintenance measures, however, in the case of significant dust rate, its interior is recommended to be cleaned with compressed air. In case of fuse replacement, use a replacement of the same parameters.

**WEEE MARK**

According to the EU WEE Directive – It is required not to dispose of electric or electronic waste as unsorted municipal waste and to collect such WEEE separately.

The power supply unit is adapted for a sealed lead-acid battery (SLA). After the operation period it must not be disposed of but recycled according to the applicable law.

GENERAL WARRANTY CONDITIONS

1. Pulsar K. Bogusz Sp.j. (the manufacturer) grants a two-year warranty for the equipment, starting from the initial product date of purchase placed on the receipt.
2. If a purchase proof is missing, a three-year warranty period is counted from the device's production date.
3. The warranty includes free-of-charge repair or replacement with an appropriate equivalent (the selection is at the manufacturer's discretion) if the malfunction is due to the manufacturer, includes manufacturing or material defects, unless such defects have been reported within the warranty period (item 1 and 2).
4. The equipment subject to warranty is to be brought to the place where it was purchased, or directly to the main office of the manufacturer.
5. The warranty applies to complete equipment, accompanied by a properly filled warranty claim with a description of the defect.
6. Should the claim be accepted, the manufacturer is obliged to provide warranty repairs, at the earliest convenience, however not later than within 14 days from the delivery to the service centre of the manufacturer.
7. The repair period mentioned in item 6 may be prolonged, if there are no technical possibilities to carry out the repairs, or if the equipment has been conditionally accepted, due to the breaking warranty terms by the claimant.
8. All the services rendered by force of the warranty are carried out at the service centre of the manufacturer, exclusively.
9. The warranty does not cover the defects of the equipment, resulting from:
 - reasons beyond the manufacturer's control,
 - mechanical damage,
 - improper storage and transport,
 - use that violates the operation manual or equipment's intended use
 - fortuitous events, including lightning discharges, power failures, fire, flood, high temperatures and chemical agents,
 - improper installation and configuration (in defiance with the manual),
10. The warranty is void in any of the following circumstances:
 - construction changes
 - repairs carried out by any unauthorized service center
 - damage or removal of warranty labels
 - modifications of the serial number
11. The liability of the manufacturer towards the buyer is limited to the value of the equipment, determined according to the wholesale prices suggested by the manufacturer on the day of purchase.
12. The manufacturer takes no responsibility for the defects that result from:
 - the damaging, malfunctioning or inability to operate the equipment
 - defects that result from using the equipment outside its stated specifications and operating parameters failing to abide by the recommendations and requirements contained in the manual, or the use of the equipment.

Pulsar K. Bogusz Sp.j.

Siedlec 150, 32-744 Łapczyca, Poland
Tel. (+48) 14-610-19-40, Fax. (+48) 14-610-19-50
e-mail: biuro@pulsar.pl, sales@pulsar.pl
http:// www.pulsar.pl, www.zasilacze.pl